

# PRODUCT SPECIFICATIONS



**Publication Date:**  
August, 2019

**Description:**  
Mercedes-Benz Sprinter  
Rear Protection Bar

**Application:**  
Mercedes-Benz VS30 Sprinter  
10/2018+  
Mercedes-Benz NCV3 Sprinter  
10/2013 - 9/2018

**Fitting:**  
Minimum 1.5 Hours  
(Non Parking Package)  
Minimum 2 Hours  
(Parking Package)

**Available:**  
Now



## Product Specification

Specifically designed for the recently released VS30 Mercedes Sprinter, SmartBar's new Vehicle Rear Protection System (VRPS) is an over bumper bar which offers outstanding vehicle protection. It perfectly complements the design and shape of the vehicle, maintains all of the factory accessories and all the while helps protect vehicle panels in the event of reversing collisions.

## Protection & Styling Characteristics:

- Superior rear protection, due to the impact absorbing hollow construction
- Minimal repair costs after impact
- Suits VS30 and NCV3 with and without factory step
- Compatible with rear parking sensors (parking sensor model must be ordered)
- Compatible with rear parking camera
- Compatible with Sprinter Rear Blind Spot Assist and Rear Cross Traffic Alert system
- Tested and rated to a safe working vertical load of 200kg
- Compatible with automatic and manual stretcher systems. Different steps are required for manual and automatic stretchers (Refer to matrix for compatibility)
- High grip moulded in tread pattern
- Fitted Weight of **24.5kg** for non-factory step vehicles
- Fitted Weight of **15kg** for factory step vehicles
- Fitted Weight of **23.5kg** for Manual Stretcher step vehicles
- Fitted Weight of **45kg** for Tow Bar step vehicles (including MC15 Tow Bar Kit)
- Bar adds 245mm to vehicle length (RB001BK bracket models) and 230mm (RB002BK bracket models)
- Over bumper for non factory step vehicles, bumper trim for factory step vehicles
- UV stabilised polymer for durability and corrosion resistance
- Styled to maintain the Vehicle's aesthetic
- Manufactured from environmentally friendly, recyclable polyethylene polymer
- Available in Black (Safety Yellow available for fleet vehicles)
- Will not catch or pool water
- Easily installed, independent of factory step
- Maintains access to spare wheel under step
- Tow Bar Step variant. Supplied with Allins MC15 Tow Bar Kit.

## Rear Vehicle Protection:

The chassis mount design comprises of a three part construction which provides strength in the event of rear impacts and also top loading when being used as a step.

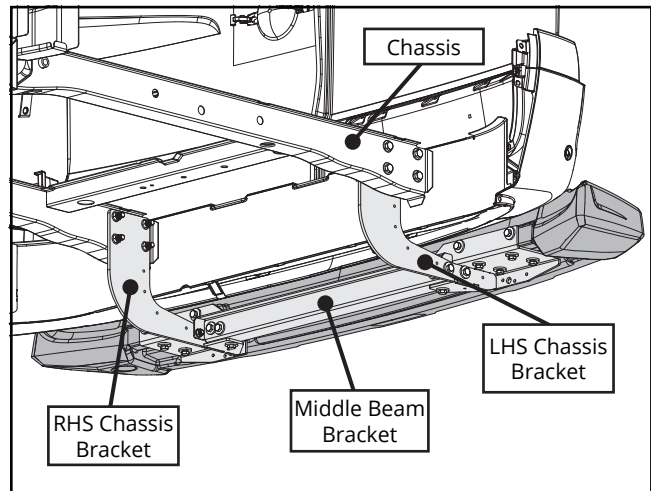

## Original Parking sensors:

The original Mercedes rear bumper / factory step parking sensors are relocated into the Rear Protection Bar, a Parking sensor compatible bar is required for this. Refer to the matrix for specific part numbers.



## Rear 360 View Camera:

The Rear Protection Bar is clearly visible on the 360deg View camera in the cabin.





## Blind Spot Assist and Rear Cross Traffic Alert:

Blind Spot Assist and Rear Cross Traffic Alert are not affected with the install of the Rear Protection Bar.



## High Grip Tread pattern:

The top of the Rear Protection Bar has a high grip tread pattern moulded in allowing for a safe step when entering the vehicle from the rear.



## Colour Options:

The Rear Protection Bar comes in Black (GG) or Safety Yellow (SY) (for fleet orders).



## Tow Bar Variant

A Rear Protection Bar variation with a clearance for a tow ball as required for Australia Standard 4177.1 - 'Caravan and light trailer towing components'

Tow Bar variant is supplied with MC15 Allins Towbar (Towing Capacity of 2000kg).



## Manual Stretcher Variant

A Rear Protection Bar variant with a section cut away to allow clearance for manual stretchers to fold down when being pushed into the rear of the vehicle.



# PART NUMBER MATRIX



## REAR PROTECTION BAR MERCEDES BENZ SPRINTER NCV3 (10/2013 - 9/2018) SPRINTER VS30 (10/2018+)

Fitting Times	Black	Safety Yellow
<b>Fitting Times</b>		
<b>2 Hours</b>		
<b>Parking Sensor Compatible<sup>1</sup></b>		
Standard Bar <sup>4</sup>	RB002GG001	RB002SY001 <sup>3</sup>
Rear Bumper Charge Plug Bar <sup>2,4</sup>	RB002GG002	-
Standard Manual Stretcher <sup>6</sup>	RB004GG003	-
Tow Bar <sup>5</sup>	RB007GG006	-
<b>Fitting Times</b>		
<b>1.5 Hours</b>		
<b>Non Parking Sensor</b>		
Standard Bar <sup>4</sup>	RB001GG001	RB001SY001 <sup>3</sup>
Rear Bumper Charge Plug Bar <sup>4</sup>	RB001GG002	-
Standard Manual Stretcher <sup>6</sup>	RB003GG003	-
Tow Bar <sup>5</sup>	RB006GG006	-

**Please note:**

<sup>1</sup> Compatible with original Mercedes parking sensors

<sup>2</sup> Required for NSW Ambulance Vehicles

<sup>3</sup> Required for VIC Ambulance Vehicles

<sup>4</sup> Compatible with Automatic Stretchers

<sup>5</sup> Supplied with Allins MC15 Tow Bar

<sup>6</sup> Compatible with Manual Stretchers