

# PRODUCT SPECIFICATIONS



**Publication Date:**

August, 2018

**Description:**

Toyota LandCruiser SmartBar

**Application:**

Toyota LandCruiser 75, 78, 79 Series models (01/90-04/07), refer last page for fitment information

**Fitting:**

Minimum 2.5 Hours

**Available:**

Made to Order

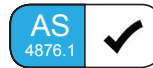

## Product Specification

Specifically designed for the Toyota LandCruiser 75, 78, 79 series as a full bumper replacement, SmartBar's Vehicle Frontal Protection System (VFPS) perfectly complements the design and shape of the vehicle, maintains most of the factory accessories and all the while provides unparalleled safety.

Designed to suit the 75, 78, 79 series model variants (01/90-04/07), the SmartBar is engineered to be the lightest and safest VFPS available; offering even more protection and safety for LandCruiser owners and importantly, pedestrians.

## Protection & Styling Characteristics:

- Meets full Australian Standard AS 4876.1-2002. Including 3.2 Road User Protection
- Weight savings provide improved fuel economy and reduced tyre, suspension and brake wear when compared to other alternatives
- Total bar weight of **36.5kg**
- Bumper replacement, easily fitted
- Superior frontal protection, due to the impact absorbing hollow construction
- Supplied with durable, clear lens Indicator Lights
- UV stabilised polymer for durability and corrosion resistance
- Styled to maintain the Vehicle's aesthetic
- Proudly designed and manufactured in Australia
- Minimal maintenance
- Minimal repair costs after impact
- Manufactured from environmentally friendly, recyclable polyethylene polymer
- Available in Black as standard, other colours available for large order quantities
- SmartBar is tested to ensure a HIC (Head Injury Criteria) figure below the Australian Standard rating of 1500, as to provide pedestrians with a higher probability of surviving a low speed impact

## Chassis Mounts:

The chassis mount design comprises of a single bracket which provides a rigid, solid and perfect fit every time.

All brackets have been tested and comply with Australian Safety Standards.

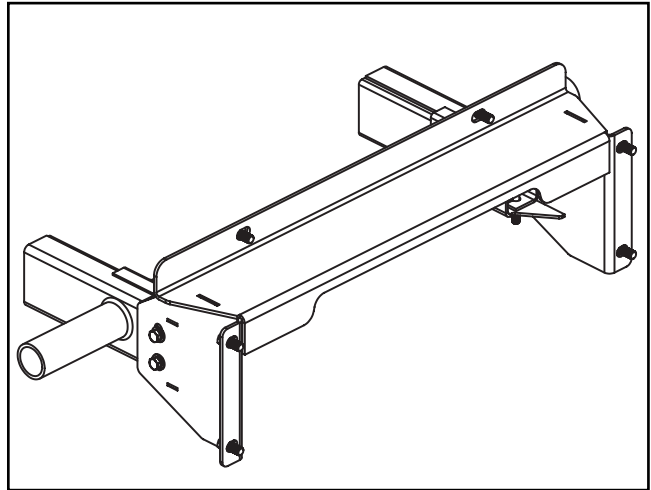

## Pedestrian Safety:

SmartBar's have been tested and proven to be less likely to cause serious injury to pedestrians than other alternatives. This is due to the hollow construction which allows the bar to absorb most of the impact along with the unique and specifically designed co-polymer material.



## Indicators:

The SmartBar is supplied with a pair of high quality indicators as standard. Spare lenses are also available for purchase in the event of a replacement.

Indicator Kit Number:  
TP44768

Replacement Lens:  
BP1165 (Left) BP1166 (Right)



# PART NUMBER MATRIX



## SMARTBAR TOYOTA LANDCRUISER 75, 78, 79 SERIES (01/90-04/07)

SmartBar Non  
Winch

Fitting Time	2.5 Hours
Vehicle	Model (Guide Only)
Toyota LC 75, 78, 79 Series <sup>1</sup>	All body types SA078BL080

Please note:

<sup>1</sup> **IMPORTANT:** Please note that this bar is made to order

