

PRODUCT SPECIFICATIONS

**Publication Date:**

August, 2018

Description:

Holden Commodore SmartBar

Application:

Holden Commodore VY & VZ models (10/02-08/06)

Fitting:

Minimum 3 Hours

Available:

Made to Order

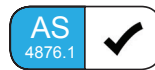

Product Specification

The Aussie icon, the Holden Commodore, is the culmination of decades of Australian manufacturing engineering.

Specifically designed for the (10/02-08/06) Holden Commodore as a full bumper replacement, SmartBar's Vehicle Frontal Protection System (VFPS) perfectly complements the design and shape of the vehicle, maintains most of the factory accessories and all the while provides unparalleled safety.

Designed to suit the VY & VZ model variants in all body types (see back page for fitment details), the SmartBar is engineered to be the lightest and safest VFPS available; offering even more protection and safety for vehicle owners and importantly, pedestrians.

Please note that the white colour is no longer available, black is available as standard with other colour options only for large quantity orders.

Protection & Styling Characteristics:

- Meets full Australian Standard AS 4876.1-2002. Including 3.2 Road User Protection
- Weight savings provide improved fuel economy and reduced tyre, suspension and brake wear when compared to other alternatives
- Air Bag Compatible
- Bumper replacement, easily fitted
- Superior frontal protection, due to the impact absorbing hollow construction
- Does not accept original vehicle fog lamps
- Supplied with Narva 100mm Driving Light
- Optional Narva 100mm Fog Light can be purchased to be used in place of Driving Light (Bar can only accommodate one option)
- UV stabilised polymer for durability and corrosion resistance
- Styled to maintain the Vehicle's aesthetic
- Proudly designed and manufactured in Australia
- Minimal maintenance
- Minimal repair costs after impact
- Manufactured from environmentally friendly, recyclable polyethylene polymer
- Available in Black as standard, other colours available for large order quantities
- SmartBar is tested to ensure a HIC (Head Injury Criteria) figure below the Australian Standard rating of 1500, as to provide pedestrians with a higher probability of surviving a low speed impact

Chassis Mounts:

The SmartBar is mounted directly to the chassis cross member for maximum strength and to achieve a solid, perfect fit every time.

All brackets have been tested and comply with Vehicle Air Bag and Australian Safety Standards.

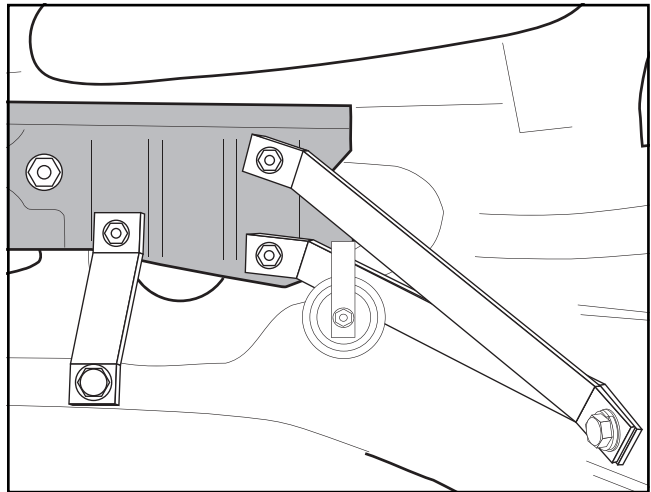

Pedestrian Safety:

SmartBar's have been tested and proven to be less likely to cause serious injury to pedestrians than other alternatives. This is due to the hollow construction which allows the bar to absorb most of the impact along with the unique and specifically designed co-polymer material.

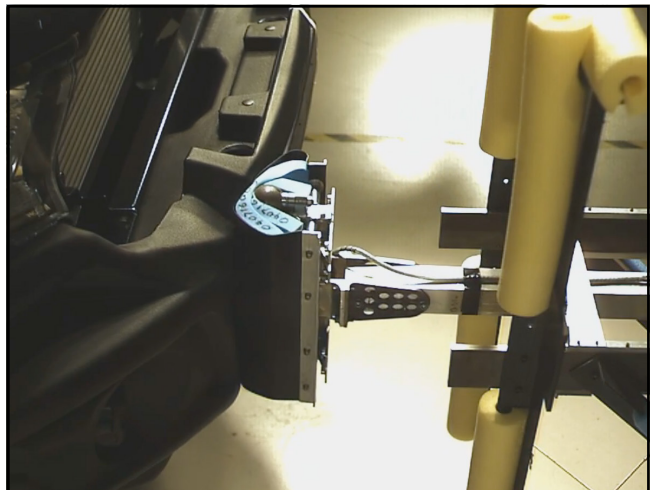

Driving Light/Fog Light:

The SmartBar is supplied with a high quality Narva Driving light as standard. There is an optional 100mm fog light that can be purchased to be used in its place (only one option can be accommodated). The lights are supplied with brackets but no loom.

100mm Narva Driving Light (supplied):
TP4878

100mm Narva Fog Light (optional):
TP23923



PART NUMBER MATRIX



SMARTBAR HOLDEN COMMODORE VY & VZ MODELS (10/02-08/06)

SmartBar Supplied 100mm Driving Light ³ Optional 100mm Fog Light ³

3 Hours 15 Mins

Fitting Time

Vehicle

Model
(Guide Only)

Holden Commodore VY & VZ (non V8 models)

Acclaim, Executive, Calais, Berlina, Adventura, SV6, Cross 6, Base Model Crewman (Sedans, Wagons and Utes)

TP4878 ³

SA082BL082

TP23923 ³

Holden Commodore VY & VZ (V8 models only) ^{1,2}

Berlina, Calais, Adventura, SV8, SS (Sedans, Wagons and Utes)

TP4878 ³

SA082BL084

TP23923 ³

Please note:

¹ Bar is made to order

² The SmartBar for the V8 is the same bar, but just requires a different bracket kit (replacement skid pan)

³ Bar can only accommodate one option. The SmartBar is supplied with the Driving Light, Fog Light can be purchased as an optional extra to be used in place of the Driving Lights. Lights are supplied with brackets, but not with loom.