

PRODUCT SPECIFICATIONS

**Publication Date:**

August, 2018

Description:

Toyota Hilux SmartBar

Application:

Toyota Hilux (03/05-07/11)

Fitting:

Minimum 3 Hours

(Non Winch)

Minimum 4 Hours

(Winch)

Available:

Now

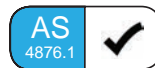

Product Specification

Designed to tackle tough terrain and unexpected obstacles, the Toyota Hilux will take you nearly anywhere you want to go; and wherever this may be, the team at SmartBar want you and your vehicle to be protected.

Specifically designed for the 03/2005-07/2011 Toyota Hilux as a partial bumper replacement, the latest model of SmartBar's Vehicle Frontal Protection System (VFPS) perfectly complements the design and shape of the vehicle, maintains most of the factory accessories and all the while provides unparalleled safety.

In addition, the ANCAP testing resulted in an offset frontal test score of 14.58 out of 16 for the Hilux with the SmartBar fitted.

Designed to suit the Workmate, SR and SR5 variants, the SmartBar is engineered to be the lightest and safest VFPS available, offering even more protection and safety for vehicle owners and importantly, pedestrians.

Protection & Styling Characteristics:

- Meets full Australian Standard AS 4876.1-2002. Including 3.2 Road User Protection
- Weight savings provide improved fuel economy and reduced tyre, suspension and brake wear when compared to other alternatives
- The five star ANCAP safety rating for the Toyota Hilux is maintained when a SmartBar is fitted. ANCAP however have not provided any information on the effects of the SmartBar on pedestrian safety
- Fitted Weight of **30.6kg for Non Winch**
- Fitted Weight of **39.4kg for Winch**
- Bar adds an approximate additional 175mm to vehicle length
- Air Bag Compatible
- Bumper trim, easily fitted
- Superior frontal protection, due to the impact absorbing hollow construction
- Not compatible with the original vehicle fog lights
- Optional 90mm fog light kit available
- Supplied with Durable LED Parker/Indicator Lights
- Supplied with 2 x Antenna Mount
- Antenna mount location on loops of the bar, up to 2 available
- Scrub bar mounting locations provided
- Winch compatible
- UV stabilised polymer for durability and corrosion resistance
- Styled to maintain the Vehicle's aesthetic
- Proudly designed and manufactured in Australia
- Minimal repair costs after impact
- Manufactured from environmentally friendly, recyclable polyethylene polymer
- Available in Black as standard, other colours available for large order quantities
- Accommodates a large range of spotlights
- Winch option SmartBar is only compatible with 4x4 vehicles
- Accommodates up to 9,500lb Winch (please refer overleaf for winch compatibility)
- SmartBar is tested to ensure a HIC (Head Injury Criteria) figure below the Australian Standard rating of 1500, as to provide pedestrians with a higher probability of surviving a low speed impact

Chassis Mounts:

The chassis mount design comprises of a two part construction which allows for three axis adjustability, to achieve a solid and perfect fit every time.

All brackets have been tested and comply with Vehicle Air Bag, Winch Maximum Pull Exertion and Australian Safety Standards.

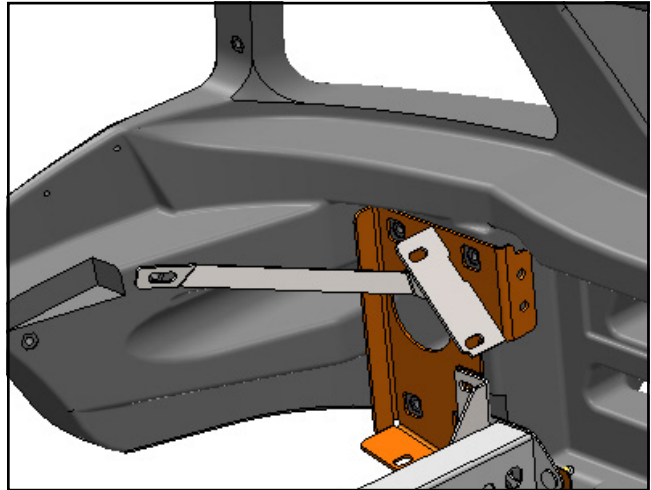

Pedestrian Safety:

SmartBar's have been tested and proven to be less likely to cause serious injury to pedestrians than other alternatives. This is due to the hollow construction which allows the bar to absorb most of the impact along with the unique and specifically designed co-polymer material.



LED Parker/Indicators:

The SmartBar is supplied with high quality LED Parker/Indicator lights as shown here.

Please note that there has been a part supply change since the bar was released. Please check the light before placing orders for replacement parts to ensure you receive the correct replacement. Current light has a chrome surround and an orange and white lens (BP50035/BP50042), whereas the previous version has a milky white lens (on display here, BP43891)



Antenna Mounts:

There are antenna mounts incorporated onto the top loops of the bull bar. The SmartBar is supplied with two antenna mount, one vertically aligned and the other horizontally. Additional antenna mounts can be purchased:

Horizontal Mount: TP50349

Vertical Mount: TP44928



Driving Light Mounts:

The SmartBar is supplied with an accessory bracket to mount driving lights, light bars and other accessories.



Winch Mount:

The SmartBar winch bracket kit is winch compatible for winches up to 9,500lb. See overleaf for full winch details.



Bumper Trim:

The bar is easily fitted as a partial bumper replacement and as such, requires a bumper trim during installation. Instructions and Trim Templates are supplied with the Bar to assist with fitment.

Please note that Safety Orange model shown is only available in large quantity orders.



Optional Fog Light:

The SmartBar is not compatible with the original vehicle fog lights. There is one 90mm light option available for purchase:

SA000FLK1: 90mm Fog Light

Please note that the bar can only accommodate one option however.



Flared Model:

All SR5 vehicle models have flares from factory. There is a flare kit required to be purchased for these models, and any other models with the flares installed.

Part Number:
SA102BL102 (Hilux Flare Kit)



Winch Model Fitment:

The SmartBar winch compatible bracket kit accommodates the following winches:

- Warn M8000, XD9000, XP9.5 and XDC 9.5.
- Warn Magnum 8
- Bushranger DV-9TH, DS9.5TH and Seal 9.5TH

The SmartBar is supplied with an accessory bracket that mounts to the bar in front of the grille. With some winches the winch control box can be mounted on the accessory bracket between the spotlights*.

Additional fit kits are required depending on the winch being fitted:

- A flip up number plate bracket is recommended for standard size number plates when SmartBar's are fitted with a winch, ARB Part number 3500630.

*Fitment of the control box to the accessory bracket will restrict the size of the lights that can be mounted. Light bars will not fit on accessory bracket at all in this instance.



Light Model Fitment:

The SmartBar accommodates the following Lights:

ARB Intensity:

- ARB Intensity 21
- ARB Intensity AR40

Bushranger Night Hawk lights:

- NHP180 (S&D) (180mm Round LED light)
- NHS055 - NHS205 (5.5 inch to 20.5 inch light bars)

IPF Lights:

- 801 Xtreme Sport Series
- 800 HID Series
- 800 Series
- 868 Series

NOTE: If a control box is fitted to the Driving Light Mount Bracket, the lights available to be fitted in the SmartBar will be heavily restricted; and it prevents completely the use of any Light Bar.



PART NUMBER MATRIX



SMARTBAR TOYOTA HILUX (03/05-07/11)

		SmartBar non winch	SmartBar winch ⁴	Optional 90mm Fog Light ⁵	Required Hilux Flare Kit
Fitting Times		3 Hours	4 Hours	15 Mins	30 Mins
Vehicle	Model (Guide Only)				
Toyota Hilux 4 x 2 & 4 x 4 ⁴ (Non Flared Vehicle Models)	Workmate, SR ²	SA100BL100	SA100BL101 ⁴	SA000FLK1	N/A
Toyota Hilux 4 x 2 & 4 x 4 ⁴ (Flared Vehicle Models)	SR ³ , SR5	SA100BL100	SA100BL101 ⁴	SA000FLK1	SA102BL102

Please note:

¹ SmartBar isn't compatible with OEM Fog Lights

² Where SR has no flares

³ Where SR does have flares

⁴ **Important:** Winch option SmartBar is only compatible with 4x4 vehicles

⁵ SmartBar will only accomodation one option