

# PRODUCT SPECIFICATIONS

**Publication Date:**

August, 2018

**Description:**

Holden Commodore SmartBar

**Application:**

Holden Commodore VE & VE2  
(08/06-05/13) Models

**Fitting:**

Minimum 3 Hours

**Available:**

Now



## Product Specification

The latest model of the Aussie icon, the Holden Commodore VE & VE2, is the culmination of 50 years of Australian manufacturing engineering.

Specifically designed for the 08/06-05/13 Holden Commodore VE & VE2 as a partial bumper replacement, the latest model of SmartBar's Vehicle Frontal Protection System (VFPS) perfectly complements the design and shape of the vehicle, maintains most of the factory accessories and all the while provides unparalleled safety.

Designed to suit the Omega, Calais, Berlina, SV6, SS model variants in all body types, the SmartBar is engineered to be the lightest and safest VFPS available; offering even more protection and safety for vehicle owners and importantly, pedestrians.

## Protection & Styling Characteristics:

- Meets full Australian Standard AS 4876.1-2002. Including 3.2 Road User Protection
- Weight savings provide improved fuel economy and reduced tyre, suspension and brake wear when compared to other alternatives
- Fitted Weight of **23kg**
- Air Bag Compatible
- Bumper replacement, easily fitted
- Superior frontal protection, due to the impact absorbing hollow construction
- Does not accept original vehicle fog lamps where applicable
- Optional 90mm Fog Light Kit available
- Uni Bar mounting location in the number plate area
- UV stabilised polymer for durability and corrosion resistance
- Styled to maintain the Vehicle's aesthetic
- Proudly designed and manufactured in Australia
- Minimal maintenance
- Minimal repair costs after impact
- Manufactured from environmentally friendly, recyclable polyethylene polymer
- Available in Black as standard, other colours available for large order quantities
- SmartBar is tested to ensure a HIC (Head Injury Criteria) figure below the Australian Standard rating of 1500, as to provide pedestrians with a higher probability of surviving a low speed impact

## Chassis Mounts:

The chassis mount design allows for two axis adjustability, to achieve a solid and perfect fit every time.

All brackets have been tested and comply with Vehicle Air Bag, Winch Maximum Pull Exertion and Australian Safety Standards.

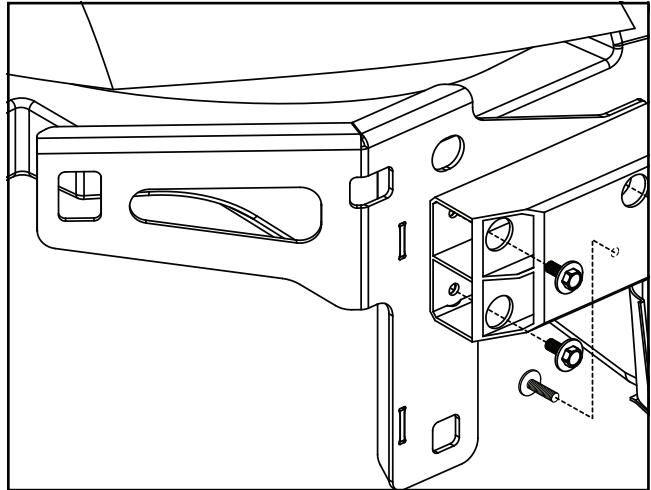

## Pedestrian Safety:

SmartBar's have been tested and proven to be less likely to cause serious injury to pedestrians than other alternatives. This is due to the hollow construction which allows the bar to absorb most of the impact along with the unique and specifically designed co-polymer material.



## Bumper Replacement:

The bar is easily fitted complete bumper replacement.



## Optional Lights:

The SmartBar accommodates one optional light accessory for additional purchase.

SA000FLK1: 90mm Narva Fog Light

Please note however that only one option can be used.



# PART NUMBER MATRIX



## SMARTBAR HOLDEN COMMODORE VE & VE2 (08/06-05/13)

SmartBar  
Optional 90mm  
Fog Light<sup>1</sup>

3 Hours

Fitting Time

Vehicle  
Model  
(Guide Only)

Holden Commodore VE & VE2<sup>1</sup>

Omega, Calais, Berlina, SV6 & SS<sup>2</sup>

SA110BL110

SA000FLK1<sup>1</sup>

Please note:

<sup>1</sup> Includes Sportswagons and Utes