

PRODUCT SPECIFICATIONS

**Publication Date:**

August, 2018

Description:

Toyota Prado 150 SmartBar

Application:

Toyota Prado 08/09 - 10/17
Models

Fitting:

2.5 Hours (Non Winch)
3 Hours (Winch)

Available:

Now



PROUDLY
AUSTRALIAN MADE

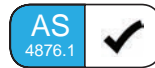

Product Specification

Specifically designed for the Toyota Prado 150 as a partial bumper replacement, SmartBar's Vehicle Frontal Protection System (VFPS) complements the design and shape of the vehicle, maintains all of the factory accessories and all the while provides unparalleled safety.

Designed to suit the 3 door and 5 door VX, ZR, GX, GXL and Kakadu models, the SmartBar is engineered to be the lightest and safest VFPS available; offering even more protection and safety for vehicle owners and importantly, pedestrians.

Protection & Styling Characteristics:

- Meets full Australian Standard AS 4876.1-2002. Including 3.2 Road User Protection
- Weight savings provide improved fuel economy and reduced tyre, suspension and brake wear when compared to other alternatives
- Fitted Weight of **27.5kg for Non Winch**
- Fitted Weight of **35.5kg for Winch**
- Air Bag Compatible
- Bumper trim, easily fitted
- Superior frontal protection, due to the impact absorbing hollow construction
- Accepts the original vehicle fog lights
- Bar is compatible with the original vehicle headlight washers
- Front parking sensors compatible with SmartBar, SA140SONAR kit must be ordered to fit parking sensors
- Supplied with Parker/Indicator Lights
- Supplied with 1 x Antenna Mount
- Antenna mount location on loops of the bar, up to 4 available
- UV stabilised polymer for durability and corrosion resistance
- Styled to maintain the Vehicle's aesthetic
- Proudly designed and manufactured in Australia
- Minimal maintenance
- Minimal repair costs after impact
- Manufactured from environmentally friendly, recyclable polyethylene polymer
- Available in Black as standard, other colours available for large order quantities
- Accommodates a large range of spotlights
- Accommodates up to 9,000lb Winch (please refer to page 6 for winch compatibility)
- SmartBar is tested to ensure a HIC (Head Injury Criteria) figure below the Australian Standard rating of 1500, as to provide pedestrians with a higher probability of surviving a low speed impact

Chassis Mounts:

The chassis mount design comprises of a two part construction which allows for three axis adjustability, to achieve a solid and perfect fit every time.

All brackets have been tested and comply with Vehicle Air Bag, Winch Maximum Pull Exertion and Australian Safety Standards.

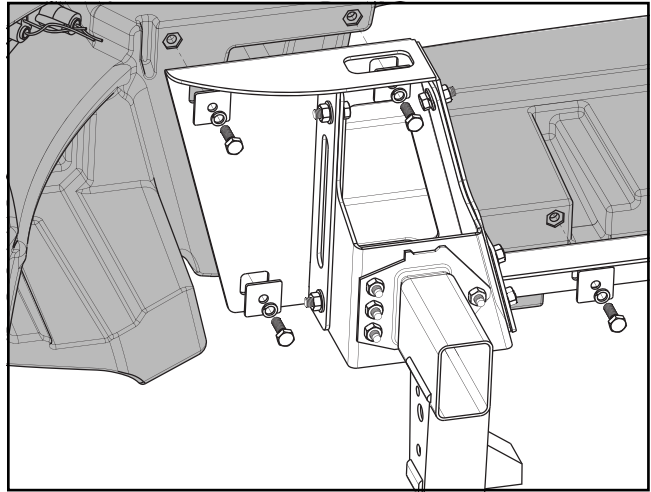

Pedestrian Safety:

SmartBar's have been tested and proven to be less likely to cause serious injury to pedestrians than other alternatives. This is due to the hollow construction which allows the bar to absorb most of the impact along with the unique and specifically designed co-polymer material.



OEM Fog Lights:

The original fog lights are compatible with the SmartBar.

Please note that the Fog Lights shown are not included with the SmartBar.



Bumper Trim:

The bar is easily fitted as a partial bumper replacement and as such, requires a bumper trim during installation. Instructions and Trim Templates are supplied with the Bar to assist with fitment. Please note that the bumper trim does not impede the position or operation of the head light washers (where applicable).



Driving Light Mounts:

The SmartBar is supplied with an accessory bracket to mount driving lights, light bars and other accessories.

To see further details on light fitment see overleaf.



Antenna Mount Bracket:

There are antenna mounts incorporated on the top of the bar. The SmartBar is supplied with a single antenna mount. Additional antenna mounts can be purchased:

TP44799 (horizontal mount)

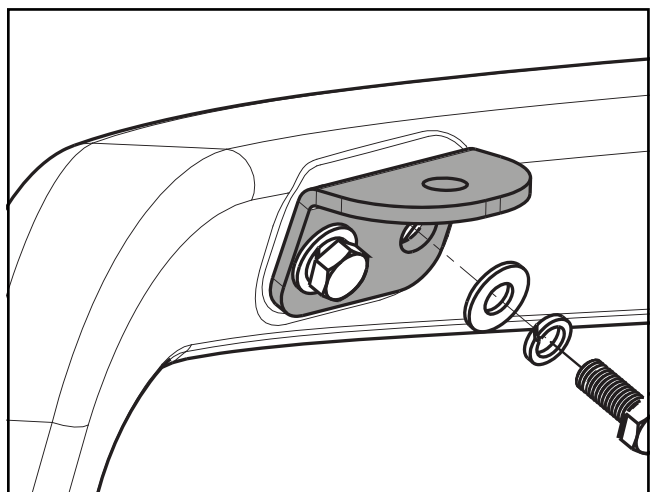

Winch Mount:

The SmartBar winch bracket kit is winch compatible for winches up to 9,000lb. See overleaf for full winch details.

Please note that the white bar is no longer available, coloured bars are only supplied subject to volume.



Sonar Kit:

Some Prado variants are supplied with front mounted parking sensors, there is a Sonar Kit (part number SA140SONAR) required to be purchased for these vehicles to enable the fitment of the sensors to the bar.

We do not recommend the fitment of aftermarket parking sonars/sensors to any SmartBar.

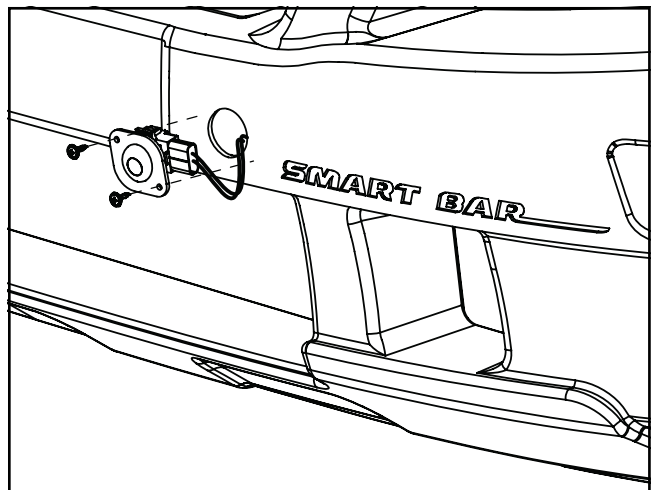

Indicator/Parker:

A pair of indicator/parker lights are supplied with the bar.

Part Number: BP1173



Winch Model Fitment:

The SmartBar for the winch compatible bracket kit accommodates the following winches:

- Warn M8000, XD9000
- Bushranger DV-9TH
- Premier VX9000

The SmartBar is supplied with an accessory bracket that mounts to the bar in front of the grille. With some winches the winch control box can be mounted on the accessory bracket between the spotlights*.

Additional fit kits are required depending on the winch being fitted:

- A flip up number plate bracket is recommended for standard size number plates when SmartBars are fitted with a winch, ARB Part number 3500630.
- Warn ZEON Platinum fitment may require part No. W94288 Enhanced Signal Kit.

*Fitment of the control box to the accessory bracket will restrict the size of the lights that can be mounted. Light bars will not fit on accessory bracket at all in this instance.



Light Model Fitment:

The SmartBar accommodates the following Lights:

ARB Intensity:

- ARB Intensity 21

Bushranger Night Hawk lights:

- NHP180 (S&D) (180mm Round LED light)
- NHS205-NHS245 (20.5 inch to 24.5 inch light bars)

IPF Lights:

- 801/901 Xtreme Sport Series
- 800/900 HID Series
- 800/900 Series
- 900 Xtreme LED Sport Series
- 868/968 Series
- 930 Super Rally

NOTE: Fitment of the control box to the accessory bracket will restrict the size of the lights that can be mounted. Light bars will not fit on accessory bracket at all in this instance.



PART NUMBER MATRIX



SMARTBAR TOYOTA PRADO 150 (08/09-08/13) & PRADO 150 (09/13-10/17)

Fitting Time	SmartBar Non Winch	SmartBar Winch	Sonar Kit
	2.5 Hours	3 Hours	45 Mins
Vehicle	Model (Guide Only)		
Toyota Prado (09/13+)	VX & ZR (3 Door), GX, GXL, VX & Kakadu (5 door) ^{1,2}	SA140BL157 SA140BL158	SA140SONAR ¹
Vehicle	Model (Guide Only)		
Toyota Prado (08/09-08/13)	VX & ZR (3 Door), GX, GXL, VX & Kakadu (5 door) ^{1,2}	SA140BL157 SA140BL158	SA140SONAR ¹

Please note:

¹ VX (3 door & 5 door), ZR and Kakadu models require Sonar Kit to be purchased for the front parking sensors

² For Kakadu models, please note that the front parking camera is obstructed by the bar when the SmartBar is installed; approximately two thirds of the view is lost. If driving lights and winch are also fitted, the camera is completely blocked