

PRODUCT SPECIFICATIONS

Date:

November, 2024

Description:

Mercedes Sprinter SpartanBar

Application:

Mercedes Sprinter
(10/2013 - 09/2018)

Fitting:

Minimum 3 Hours (Non Winch)
Minimum 4 Hours (Winch)

Available:

Now



Product Specification

Mercedes have released the second face-lift of the Sprinter van, which feature a number of changes in the visual appearance of the vehicle. The team at SmartBar have developed a new frontal protection system styled to suit the Sprinter which is now available.

Designed for the Sprinter as a full bumper replacement, the latest model of SmartBar's Vehicle Frontal Protection System (VFPS) perfectly complements the design and shape of the vehicle. The SmartBar maintains all of the factory accessories and all the while providing unparalleled safety.

Designed to suit the Sprinter, the SmartBar is engineered to be the lightest bull bar available; offering even more protection and safety for Sprinter owners and pedestrians.

Protection & Styling Characteristics:

- Meets full Australian Standard AS 4876.1-2002. Including 3.2 Road User Protection
- Weight savings provide improved fuel economy and reduced tyre, suspension and brake wear when compared to other alternatives
- Fitted Weight of **35kg for Non Winch**
- Fitted Weight of **37kg for Non Winch (Ambulance)**
- Fitted Weight of **50kg for Winch**
- Full Bumper replacement
- Air Bag Compatible
- SmartBar adds approximately 150mm to overall length of the vehicle
- Superior frontal protection, due to the impact absorbing hollow construction
- Removeable plug for access to the original tow point
- UV stabilised polymer for durability and corrosion resistance
- Proudly designed and manufactured in Australia
- Durable LED Parker/Indicator Lights
- Supplied with 1 x Antenna Mount
- Antenna mount locations are found behind the loops of the bar, up to 2 available
- Styled to maintain the Vehicle's aesthetics
- Minimal maintenance
- Minimal repair costs after impact
- Manufactured from environmentally friendly, recyclable polyethylene polymer
- Available in Black as standard, other colours available for large order quantities
- Accommodates a large range of spotlights
- Accommodates up to 9,500lb Winch
- SmartBar is tested to ensure a HIC (Head Injury Criteria) figure below the Australian Standard rating of 1500, as to provide pedestrians with a higher probability of surviving a low speed impact

Chassis Mounts:

The chassis mount design for the Mercedes 2013+ series SmartBar comprises of a two part construction which allows for three axis adjustability, to achieve a solid and perfect fit every time.

All brackets have been tested and comply with Vehicle Air Bag, Winch Maximum Pull Exertion and Australian Safety Standards.

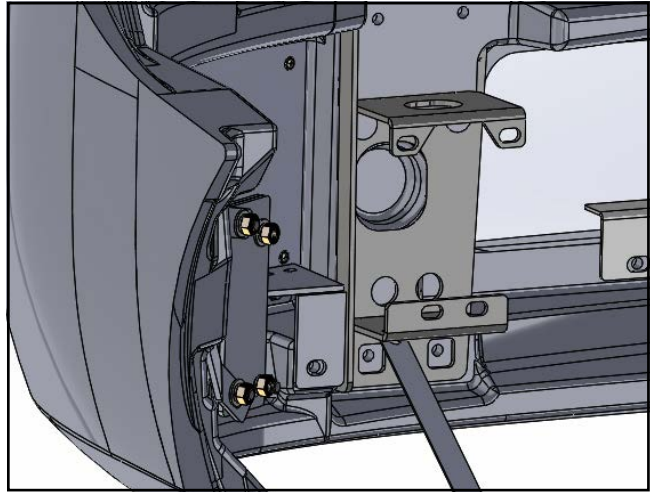

Pedestrian Safety:

SmartBar's have been tested and proven to be less likely to cause serious injury to pedestrians than other alternatives. This is due to the hollow construction which allows the bar to absorb most of the impact along with the unique and specifically designed co-polymer material.



Tow Point Access:

The original tow point "I" bolt can be inserted into the chassis through a hole in the SmartBar. When not required this hole is covered with a removable plug.



Antenna Mounts:

There is an antenna mount incorporated onto the top loop of the bull bar on both sides of the vehicle. The SmartBar is supplied with a single antenna mount. Additional antenna mounts can be purchased:

Horizontal Mounts: TP49459 (1 x supplied, additional mounts available for purchase)



Driving Light Mounts:

The SmartBar is supplied with an accessory bracket to mount driving lights, light bars and other accessories.



Winch Mount:

The SmartBar winch bracket kit designed to suit the BushRanger Seal 9.5TH (9,500 lb) Winch.



Fog & Driving Lights, LED Parker/ Indicator Lights:

The original Sprinter fog lights are compatible with the SmartBar. If required, an optional 100mm driving light kit can be installed in this area in place of the fog lights. The Part number for this driving light kit is SA155-DLK.

A durable LED Parker/Indicator is also supplied with the bar (BP50035/BP50042).



Collision Avoidance Kit:

The SmartBar accommodates the fitment of the OE collision prevention assist. Please note however, this kit is fitted in the same area of the bar that for Ambulance spec vehicles, the siren is located. Therefore the kit cannot be used with siren fitted. It is recommended that in the instance that both need to be fitted, one siren is fitted on the passenger side; and the collision avoidance is left to be fitted on driver's side.



Full Bumper Replacement:

The SmartBar is a full bumper replacement which is specifically designed to maintain the aesthetic of the Mercedes Sprinter.



Winch Model Fitment:

The SmartBar for the Mercedes Sprinter 2013+ winch compatible bracket kit accommodates the following winches:

- Bushranger Seal 9.5TH

The SmartBar is supplied with an accessory bracket that mounts to the bar in front of the grille. The winch control box can be mounted on the accessory bracket between the spotlights.

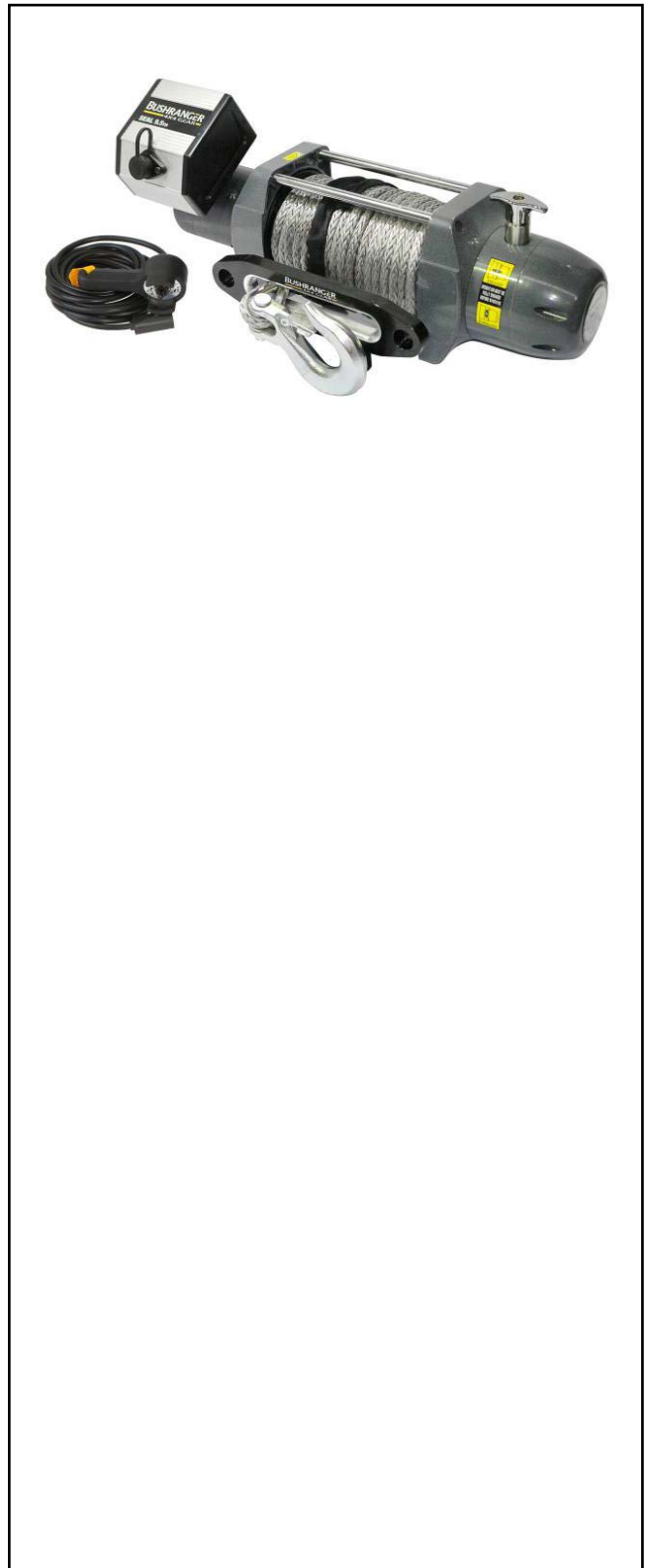

Light Model Fitment:

The SmartBar for the Mercedes Sprinter models accommodates the following Lights:

ARB Intensity:

- ARB Intensity 21
- ARB Intensity 32
- ARB Intensity Light Bar AR40 (requires pedestal mount)

Bushranger Night Hawk:

- NHP180 (S&D) (180mm Round LED light)
- NHS055-NHS245 (5.5 inch to 24.5 inch light bars)

IPF:

- 801/901 Xtreme Sport Series
- 800/900 HID Series
- 800/900 Series
- 900 Xtreme LED Sport Series

Light Force:

- 170 Striker
- Genesis
- XGT

Hella:

- Rallye 4000
- Rallye 4000 Compact
- Comet 450

NOTE: If a control box is fitted to the Driving Light Mount Bracket, the lights available to be fitted in the SmartBar will be heavily restricted; and it prevents completely the use of any Light Bar.





PART NUMBER MATRIX

SPARTANBAR MER- CEDES SPRINTER 10/13 - 09/18

Fitting Time	3 Hours	4 Hours	15 Mins
Mercedes Sprinter Non Winch	SpartanBar Non Winch	SpartanBar Winch	Collision Avoidance Kit
Model (Guide Only)			
Panel Van, Minibus, Single & Dual Cab Chassis ¹	SA155BL156		SA155-CAK ^{2,3}
Ambulance Spec ¹	SA155BL155		SA155-CAK ^{2,3}
Mercedes Sprinter Winch			
Model (Guide Only)			
Panel Van, Minibus, Single & Dual Cab Chassis ¹		SA185BL185	SA155-CAK ^{2,3}

Please note:

- ¹ Not compatible with OEM Parking Sensors
- ² Required for vehicles with OE Collision Prevention Assist
- ³ This kit cannot be used with siren fitted on driver's side of the vehicle however