

PRODUCT SPECIFICATIONS

**Date:**

August, 2018

Description:

Triton MQ Series SmartBar

Application:

Mitsubishi Triton MQ
(05/15 - 10/18)

Fitting:

Minimum 4 Hours (Non Winch)
Minimum 4.5 Hours (Winch)

Available:

Now



Product Specification

For over 30 years the Mitsubishi Triton has helped Australian's get the hard jobs done. Engineered to deliver power, performance, towing capacity and technology, this is a tough ute that is as easy to handle as a passenger car and can handle anything that the tough Australian roads may throw at it; and no matter where you are, the team at SmartBar is here to ensure that you, your passengers and your vehicle stay protected.

Specifically designed for the 2015+ Mitsubishi Triton as a partial bumper replacement, this model of SmartBar's Vehicle Frontal Protection System (VFPS) perfectly complements the design and shape of the vehicle. The SmartBar maintains most of the factory accessories and all the while provides unparalleled safety.

Designed to suit the GLX, GLS and Exceed variants, the SmartBar is engineered to be the lightest and safest bumper replacement VFPS available; offering even more protection and safety for Triton owners and pedestrians.

Protection & Styling Characteristics:

- Meets full Australian Standard AS 4876.1-2002. Including 3.2 Road User Protection
- Weight savings provide improved fuel economy and reduced tyre, suspension and brake wear when compared to other alternatives
- Fitted Weight of **33kg for Non Winch**
- Fitted Weight of **42kg for Winch**
- Bar adds an approximate additional 215mm to vehicle length
- Approach angle is 30° with bar fitted
- Air Bag Compatible
- Accepts the original vehicle fog lights
- Supplied with Durable LED Parker/Indicator Lights
- Optional daytime driving light kit and 90mm fog light kit available
- Features durable under wing guards, in black
- Bumper trim, easily fitted
- Superior frontal protection, due to the impact absorbing hollow construction
- Supplied with 1 x Antenna Mount
- Antenna mount location on top bars, up to 4 available
- UV stabilised polymer for durability and corrosion resistance
- Styled to maintain the Vehicle's aesthetic
- Proudly designed and manufactured in Australia
- Minimal maintenance
- Minimal repair costs after impact
- Manufactured from environmentally friendly, recyclable polyethylene polymer
- Available in Black as standard, other colours available for large order quantities
- Accommodates a large range of spotlights
- Accommodates up to 10,000lb Winch
- SmartBar is tested to ensure a HIC (Head Injury Criteria) figure below the Australian Standard rating of 1500, as to provide pedestrians with a higher probability of surviving a low speed impact

Chassis Mounts:

The chassis mount design for the Triton SmartBar comprises of a two part construction which allows for three axis adjustability, to achieve a solid and perfect fit every time.

All brackets have been tested and comply with Vehicle Air Bag, Winch Maximum Pull Exertion and Australian Safety Standards.

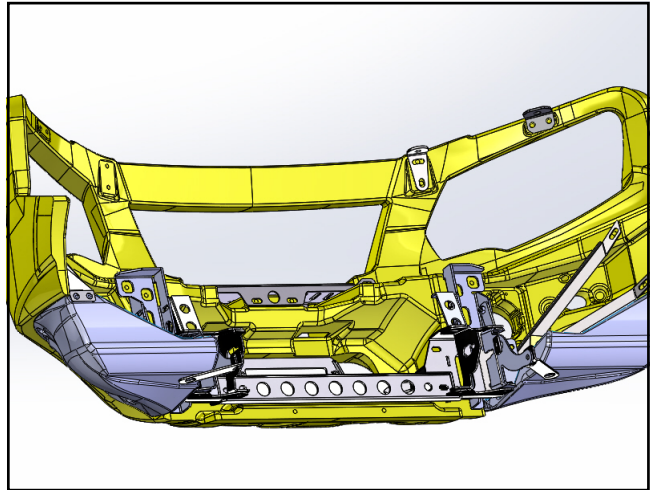

Pedestrian Safety:

SmartBar's have been tested and proven to be less likely to cause serious injury to pedestrians than other alternatives. This is due to the hollow construction which allows the bar to absorb most of the impact along with the unique and specifically designed co-polymer material.

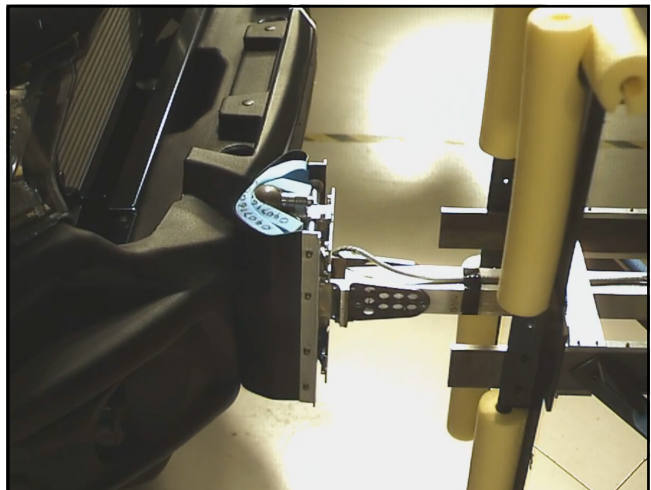

Winch Mount:

The SmartBar winch bracket kit is winch compatible for winches up to 10,000lb. See overleaf for full winch details.



Antenna Mounts:

There are antenna mounts incorporated on the top loops of the bull bar. The SmartBar is supplied with a single antenna mount. Additional antenna mounts can be purchased:

Vertical Mount: TP44928 (supplied)
Horizontal Mount: TP50585 (optional extra)



Driving Light Mounts:

The SmartBar is supplied with an accessory bracket to mount driving lights, light bars and other accessories.

The mount includes pinning holes for the Intensity lights.

To see further details on light fitment see overleaf.



Fog Lights:

The original Triton Fog Lights are compatible with the SmartBar.

Please note that the Fog Lights shown are not included with the SmartBar.

An optional Fog Light can be purchased for vehicles that aren't fitted with Fog Lights in the bumper. Kit Number TP23923.



Day Time Running Lights:

The SmartBar design incorporates high quality Hella Day Time Running Lights (DRL) to provide additional safety when driving during daylight hours. The DRL is designed to turn on with the vehicle ignition and off when the vehicle parker lights are turned on.

DRL's are supplied as standard for the Exceed SmartBar, and are an optional accessory for other models. Please note that a maximum of 2 DRLs are permitted as per ADR requirement.



Under Wing Guards:

Durable under body guards attach to the bar and provide extra protection for the vehicle components and bar brackets.



Indicators & Bumper Trim:

The SmartBar is supplied with a pair of high quality LED indicator lamps (6821287) as standard.

The bar is easily fitted as a partial bumper replacement and as such, requires a bumper trim during installation. Instructions and Trim Templates are supplied with the Bar to assist with fitment.



Winch Model Fitment:

The SmartBar winch compatible bracket kit accommodates the following winches:

- Warn M8000, XD9000, XP9.5 and XDC 9.5
- Warn ZEON 8, 8-S, 10, 10-S
- Warn ZEON Platinum 10, 10-S
- Warn Magnum 10
- Bushranger DV-9TH, DS9.5TH and Seal 9.5TH

The SmartBar is supplied with an accessory bracket that mounts to the bar in front of the grille. With some winches the winch control box can be mounted on the accessory bracket between the spotlights*.

Additional fit kits are required depending on the winch being fitted:

- A flip up number plate bracket is recommended for standard size number plates when SmartBars are fitted with a winch, ARB Part number 3500630.
- Warn ZEON Platinum fitment may require part No. W94288 Enhanced Signal Kit.

*Fitment of the control box to the accessory bracket will restrict the size of the lights that can be mounted. Light bars will not fit on accessory bracket at all in this instance.



Light Model Fitment:

The SmartBar accommodates the following Lights:

ARB Intensity:

- ARB Intensity 21
- ARB Intensity Light Bar AR40 (requires pedestal mount)

Bushranger Night Hawk lights:

- NHP180 (S&D) (180mm Round LED light)
- NHS055-NHS205 (5.5 inch to 20.5 inch light bars)

IPF Lights:

- 801/901 Xtreme Sport Series
- 800/900 HID Series
- 800/900 Series
- 900 Xtreme LED Sport Series
- 868/968 Series
- 930 Super Rally

NOTE: If a control box is fitted to the Driving Light Mount Bracket, the lights available to be fitted in the SmartBar will be heavily restricted; and it prevents completely the use of any Light Bar.



PART NUMBER MATRIX

SMARTBAR MITSUBISHI TRITON (05/15 - 10/18)

		SmartBar Non Winch	SmartBar Winch	Optional Day Time Running Lights	Optional Fog Light Kit ¹
Fitting Time		4 Hours	4.5 Hours	45 Mins	15 Mins
Vehicle	Model (Guide Only)				
Single Cab, Club Cab, Double Cab (4 x 2 & 4 x 4)	GLX, GLX+ ³	SA166BL166	SA166BL167	6821287	SA000FLK1
Double Cab (4 x 2 & 4 x 4)	GLS, GLS Sports & Exceed ³	SA177BL166	SA177BL167	N/A ²	SA000FLK1

Please note:

¹ Bar can only accommodate one option, or the original bumper's Fog Light
² Not applicable because the DRL's are supplied as standard with the bar for the GLS and Exceed
³ Compatible with OEM Fog Lights