

# PRODUCT SPECIFICATIONS



## Publication Date:

January, 2019

## Description:

VS30 Sprinter Smartbar

## Application:

Mercedes Benz VS30 Sprinter  
10/2018 - 03/2024

## Fitting:

Minimum 4 Hours  
(Non Parking Package)  
Minimum 5 Hours  
(Parking Package)  
Refer Matrix for Accessory Fitup

## Available:

Now



## Product Specification

Specifically designed for the Mercedes Sprinter VS30\*, the SmartBar's Vehicle Frontal Protection System (VFPS) is a complete bumper replacement that complements the design and shape of the vehicle, maintains all of the factory accessories and all the while provides unparalleled safety.

Designed to suit the VS30 Panel Van along with the Minibus and Cab Chassis in any length and roof configuration\*, the SmartBar is engineered to be the lightest and safest VFPS available; offering even more protection and safety for vehicle owners and importantly pedestrians.

Additionally the SmartBar is compatible with all on board safety systems including the factory standard Active Brake Assist with Autonomous Emergency Braking, optional Parking Package with 360 degree camera; and also providing the necessary clearance to the AdBlue DEF Tank.

Suits both standard and Ambulance vehicles\*, refer to the last page for more specific information.

**\*Does not fit front-wheel drive models & vehicles fitted with LED headlights.**

---

## Protection & Styling Characteristics:

- Meets full Australian Standard AS 4876.1-2002. Including 3.2 Road User Protection
- Weight savings provide improved fuel economy and reduced tyre, suspension and brake wear when compared to other alternatives
- SmartBar is tested to ensure a HIC (Head Injury Criteria) figure below the Australian Standard rating of 1500, as to provide pedestrians with a higher probability of surviving a low speed impact
- Fitted Weight of **45.5kg for Ambulance Vehicles**
- Fitted Weight of **44kg for Non Parking Package Vehicles**
- Fitted Weight of **44.5kg for Parking Package Vehicles**
- Bar adds 190mm to vehicle length
- 17° approach angle at centre (21° approach angle from factory)
- Air Bag Compatible
- Bumper replacement, easily fitted
- Superior frontal protection, due to the impact absorbing hollow construction
- Supplied with Smartbar 4-in-1 Light; includes daytime running light, fog, parker & indicator\*
- Supplied with 1 x LHS Antenna Mount
- Antenna mount location on loops of the bar, up to 2 available
- UV stabilised polymer for durability and corrosion resistance
- Styled to maintain the Vehicle's aesthetic
- Proudly designed and manufactured in Australia
- Minimal maintenance
- Minimal repair costs after impact
- Manufactured from environmentally friendly, recyclable polyethylene polymer
- Accommodates a number of spotlights
- Compatible with front parking sensors, 360 degree camera and AdBlue DEF Tank

\*Additional wiring may be required for all functions, please refer to fitment matrix on last page for more information.

## Chassis Mounts:

The chassis mount design comprises of several unique brackets which allows for three axis adjustability while still providing clearance to all the internal components, support to the chassis and offering superior rigidity to the bar on the vehicle.

All brackets have been tested and comply with Vehicle Air Bag compatibility and Australian Safety Standards.

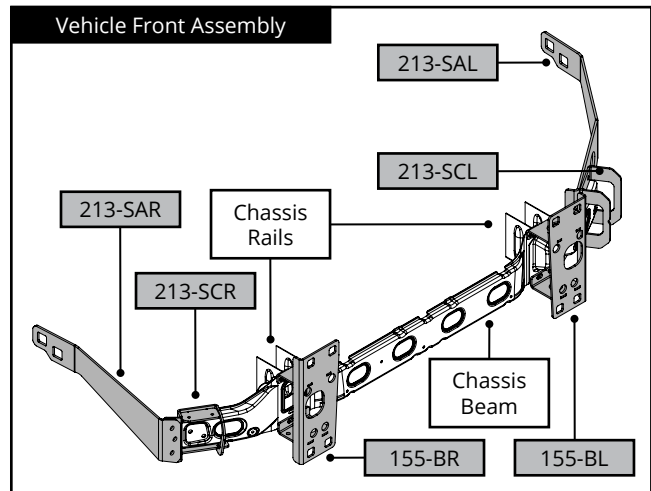

## Pedestrian Safety:

SmartBar's have been tested and proven to be less likely to cause serious injury to pedestrians than other alternatives. This is due to the hollow construction which allows the bar to absorb most of the impact along with the unique and specifically designed co-polymer material.

SmartBar is tested to ensure a HIC (Head Injury Criteria) figure below the Australian Standard rating of 1500.



## AEB Sensor:

All VS30 Sprinter's come supplied with the Active Brake Assist/Autonomous Emergency Braking Safety Feature as standard.

Please note, the sensor for the AEB module is positioned directly in the middle of the lower grille opening.



## Tow Point Extension:

A removeable plug is supplied as standard, which can be screwed out and removed for tow point access in the vehicle.

The 116-TE Tow Point Extension (supplied in bracket kit) is required to screw into the tow point to provide access through the relief in the SmartBar.



## Accessories Mount:

The SmartBar is supplied with an accessory bracket to mount driving lights, 360 degree camera relocation module (where applicable) and other accessories.

To see further details on light fitment see overleaf.



## Parking Sensors:

Vehicles fitted with the Parking Package including 360 degree camera come supplied with 6 x parking sensors.

The SmartBar is compatible with these vehicles.

Part Number: SA213GG213



## Spot Light Specifications:

We recommend that the diameter of each spotlight should not exceed 185mm in diameter.

This is to ensure that the airflow to the vehicle's cooling systems is adequate.

Please note that light bars will not be compatible with vehicles fitted with the Parking Package.



## Aerial Mount Bracket:

There are aerial mounts incorporated into the side arms of the SmartBar. A single aerial mount bracket (LHS) is supplied with the SmartBar. An additional RHS mount bracket is available for purchase.

LHS Bracket (Supplied): SA213AML (pictured)  
RHS Bracket (Optional): SA213AMR



## SmartBar 4-in-1 Light:

Supplied, with our 4-in-1 SmartBar Light, this light has daytime running light, fog light, parking light and indicator functions. The 4-in-1 Light comes with a 5 year warranty.

All non-Ambulance vehicles require an additional harness and fuse kit to be able to correctly install the lights. Refer fitment matrix for full information regarding wiring requirements.



---

### 360 Degree Camera:

Included in the Mercedes JB6 Parking Package is the 360 degree camera to assist with parking and manoeuvring.

For vehicles fitted with this package, the camera is required to be relocated from the lower part of the grille, to inside the housing that is supplied standard with the SA213 SmartBar.



### Underwing Panels:

Underwing panels have been designed to provide additional protection to the underside of the vehicle, and provide a mounting point for the wheel arch liners.



### Complete Bumper Replacement:

The SmartBar is easily fitted as a complete bumper replacement, meaning that no trimming is required during installation.





# PART NUMBER MATRIX

## SMARTBAR MERCEDES BENZ SPRINTER VS30 (10/2018- 03/2024)

Fitting Times	4 Hours	5 hours	1.5 Hours	0.25 Hours
<b>SmartBar Non Winch</b>				
Mercedes Sprinter VS30 - Standard <sup>1</sup> Vehicles	SA214GG244 <sup>1</sup>	SA213GG244 <sup>1</sup>	SA213WN <sup>4</sup> or SA213WF <sup>3</sup>	SA213-AMR <sup>5</sup>
Mercedes Sprinter VS30 - Ambulance Vehicles	SA214GG213	SA213GG213	SA213WN <sup>4</sup> or SA213WF <sup>3</sup>	SA213-AMR <sup>5</sup>
<b>Fitting Times</b>	<b>5 Hours</b>	<b>6 Hours</b>	<b>1.5 Hours</b>	
<b>SmartBar Winch</b>				
Mercedes Sprinter VS30 - Standard <sup>1</sup> Vehicles	SA214GG219 <sup>1</sup>	SA213GG219	SA213WN <sup>4</sup> or SA213WF <sup>3</sup>	SA213-AMR <sup>5</sup>
Mercedes Sprinter VS30 - Ambulance Vehicles	SA214GG219	SA213GG219	SA213WN <sup>4</sup> or SA213WF <sup>3</sup>	SA213-AMR <sup>5</sup>

**Please note:**

- <sup>1</sup>The standard SmartBar (non-ambulance) includes a Siren Hole Cover Mesh Kit.
- <sup>2</sup>This 4-in-1 Light Harness Kit aids in wiring the lights to the vehicle and will speed up and simplify the installation.
- <sup>3</sup>SA213WF light wiring harness is for vehicles with original Mercedes fog lights
- <sup>4</sup>SA213WN light wiring harness is for vehicles without original Mercedes fog lights
- <sup>5</sup>SmartBar supplied with LHS antenna mount or, standard RHS can be purchased separately
- <sup>6</sup>Ambulance bar is supplied with siren mounts for siren installment.

**Does not fit front-wheel drive models & vehicles fitted with LED headlights.**