

PRODUCT SPECIFICATIONS

Publication Date:

May, 2024

Description:

Toyota HiLux SpartanBar

Application:

Toyota HiLux 06/2020-12/2023

Fitting:

Minimum 3 Hours (Non Winch)

Minimum 4 Hours (Winch)

Refer to part matrix for accessory fitup

Available:

Now



Product Specification

Toyota has released the long-awaited facelift models of their latest generation HiLux, reinvigorating the range with an updated bumper and grille design.

The Hilux SpartanBar has been tested and fitment is confirmed for the 2020+ facelift models Workmate, SR and SR5 (see matrix for full model specific fitment information). Engineered to be the lightest and safest VFPS available, offering superior protection and safety for HiLux owners and pedestrians.

The SpartanBar maintains all of the Hilux safety systems and driver aids such as the Lane Departure Assist and Lane Tracing (LDA), Pre-Collision System (PCS), Road Sign Assist (RSA) and Dynamic Radar Cruise Control (Adaptive Cruise) (DRCC).

It has also been updated to be compatible with Front Parking Sensors and Front Parking Camera.

Protection & Styling Characteristics:

- Meets full Australian Standard AS 4876.1-2002. including 3.2 Road User Protection
- Weight savings provide improved fuel economy and reduced tyre, suspension and brake wear when compared to other alternatives
- Fitted Weight of **32kg for Non Winch**
- Fitted Weight of **42kg for Winch**
- Bar adds an approximate additional 230mm to vehicle length
- Air Bag compatible
- Bumper trim easily fitted
- Superior frontal protection, due to the impact absorbing hollow construction
- Supplied with durable LED Parker/Indicator lights
- Supplied with 1 x Antenna mount
- Antenna mount location on loops of the bar, up to 4 available
- UV stabilised polymer for durability and corrosion resistance
- Styled to maintain the vehicle's aesthetic
- Proudly designed and manufactured in Australia
- Minimal maintenance
- Minimal repair costs after impact
- Manufactured from environmentally friendly, recyclable polyethylene polymer
- Available in Black as standard, other colours available for large order quantities
- Accommodates a large range of spotlights
- Accommodates up to 10,000lb Winch (please refer overleaf for winch compatibility)
- Compatible with ARB Under Vehicle Protection
- Compatible with ARB Recovery Points
- SpartanBar is tested to ensure a HIC (Head Injury Criteria) figure below the Australian Standard rating of 1500, as to provide pedestrians with a higher probability of surviving a low speed impact
- Compatible with SmartBar All-in-1 Light Kit
- SpartanBar is compatible with vehicles that are equipped with Toyota Safety Sense Technology (see Light and Winch fitments pages for compatibility)
- Does not accept the original vehicle fog lights - see Part Matrix for replacement fog lights
- Compatible with original Toyota Front parking sensors - see Part Matrix for part numbers
- Compatible with original front parking camera. Optional kit required - see Part Matrix for part numbers.

Chassis Mounts:

The chassis mount design for the SpartanBar comprises of a two part construction which allows for three axis adjustability, to achieve a solid and perfect fit every time.

All brackets have been tested and comply with Vehicle Air Bag, Winch Maximum Pull Exertion and Australian Safety Standards.

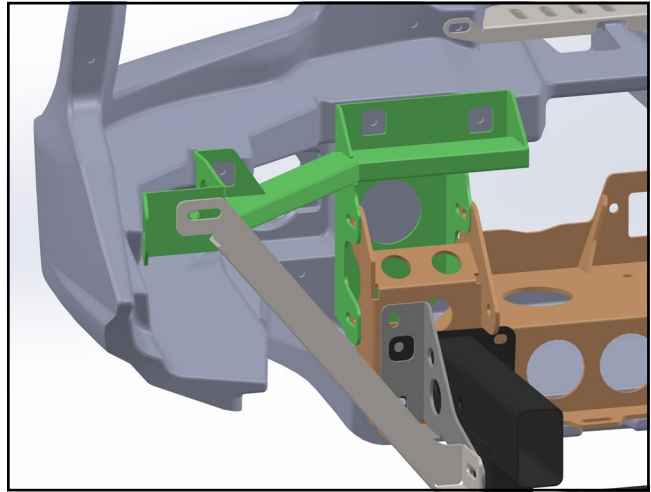

Pedestrian Safety:

SmartBar's have been tested and proven to be less likely to cause serious injury to pedestrians than other alternatives. This is due to the hollow construction which allows the bar to absorb most of the impact along with the unique and specifically designed co-polymer material.

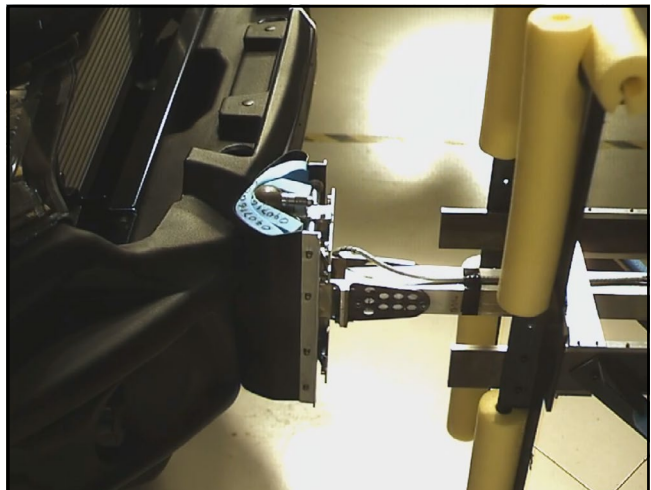

Recovery Point:

The HiLux SpartanBar, in both winch and non winch configurations, is compatible with the ARB recovery points to assist with vehicle recovery. Shown in red here.

Narrow body SA172 bars are not compatible with ARB recovery points



Under Vehicle Protection:

The HiLux SpartanBar in both winch and non winch configurations, is compatible with the ARB Under Vehicle Protection (UVP) and Under Vehicle Armour (UVA).



Day Time Running Lights:

The SpartanBar design incorporates high quality Hella Day Time Running Lights (DRL) to provide additional safety when driving during daylight hours. The DRL is designed to turn on with the vehicle ignition and off when the vehicle parker lights are turned on.

DRL's are supplied as standard for the SR5 SpartanBar, and are an optional accessory for other models. Please note that a maximum of 2 DRLs are permitted as per ADR requirement.



Driving Light Mounts:

The SpartanBar is supplied with an accessory bracket to mount driving lights and light bars.

The mount includes pinning holes for the Intensity lights. For further details on light fitment see overleaf.



IMPORTANT: To be compatible with the safety sense systems individual driving lights must have a minimum distance of 100mm between them.



Antenna Mounts:

There are antenna mounts incorporated on the top loops of the bull bar. The SpartanBar is supplied with a single antenna mount. Additional antenna mounts can be purchased:

Vertical Mount: SAAMB21 (supplied)

Horizontal Mount: SAAMB22 (optional extra)



Fog Lights:

The original HiLux fog lights are not compatible with the SpartanBar.

Replacement Fog Lights are optional for Workmate and SR models.

Replacement Fog Lights are required for SR5 models.

See part matrix for details.



Winch Mount:

The SpartanBar winch bracket kit is winch compatible for winches up to 10,000lb. See overleaf for full winch details.

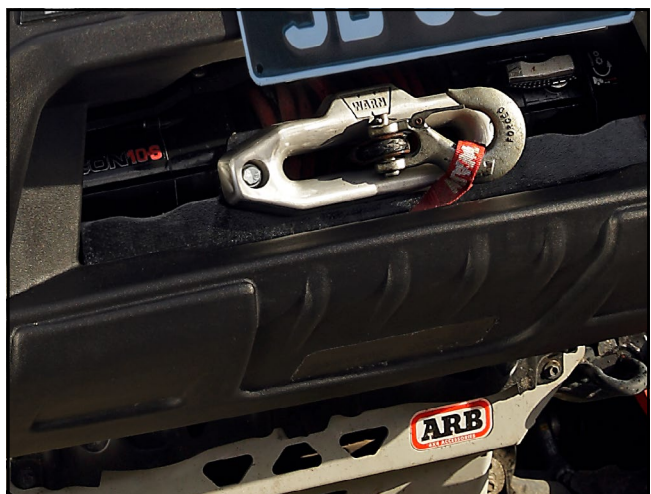

Toyota Safety Sense:

The SpartanBar is compatible with vehicles that are equipped with Toyota Safety Sense Technology, including:

- LDA: Lane Departure Assist and Lane Tracing
- PCS: Pre-Collision System
- RSA: Road Sign Assist
- DRCC: Dynamic Radar Cruise Control (Adaptive Cruise)



IMPORTANT: To be compatible with the safety sense systems individual driving lights must have a minimum distance of 100mm between them.

2020 Facelift infill kit:

A new bumper infill kit has been developed for the Hilux 2020 face lift.

Part Number: SA268FK

Parking Sensors:

The SpartanBar is now compatible with the original Toyota front parking sensors. See part matrix for details.



Camera Relocation Kit:

A camera Relocation kit is required for Hilux with Front parking camera

Part No. SA170CRK

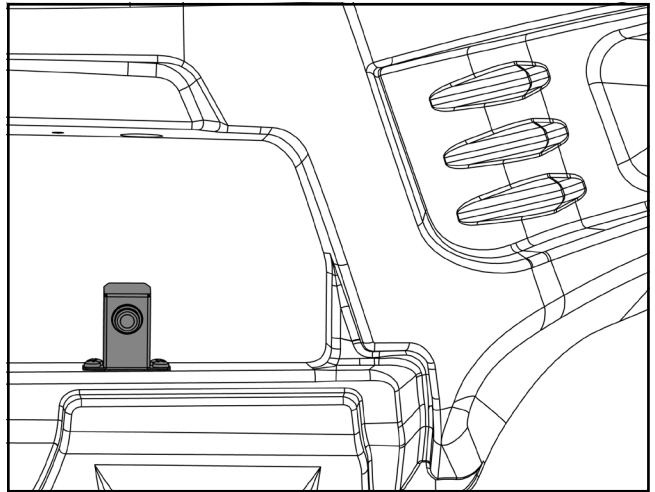

Winch Model Fitment:

The StealthBar winch compatible bracket kit accommodates the following winches:

- Bushranger REVO 10lb
- Bushranger COVERT 10lb
- Warn ZEON 8, 8-S, 10, 10-S
- Warn ZEON Platinum 10 and 10-S
- Warn VR EVO

Additional fit kits are required depending on the winch being fitted:

- A flip up number plate bracket is recommended for standard size number plates when SmartBar's are fitted with a winch, ARB Part number 3500630.
- Warn ZEON Platinum fitment may require part No. W94288 Enhanced Signal Kit.

! IMPORTANT: Fitment of the Control Box to the accessory bracket may interfere with Toyota Safety Sense technology. SmartBar recommends mounting the Control Box elsewhere.



Light Model Fitment:

The StealthBar for the Toyota HiLux models accommodates the following lights:

ARB Intensity:

- ARB Intensity 21¹
- ARB Solis 21¹

Bushranger Night Hawk lights:

- VLI 7" driving lights¹



¹IMPORTANT: To be compatible with the safety sense systems individual driving lights must have a minimum distance of 100mm between them.

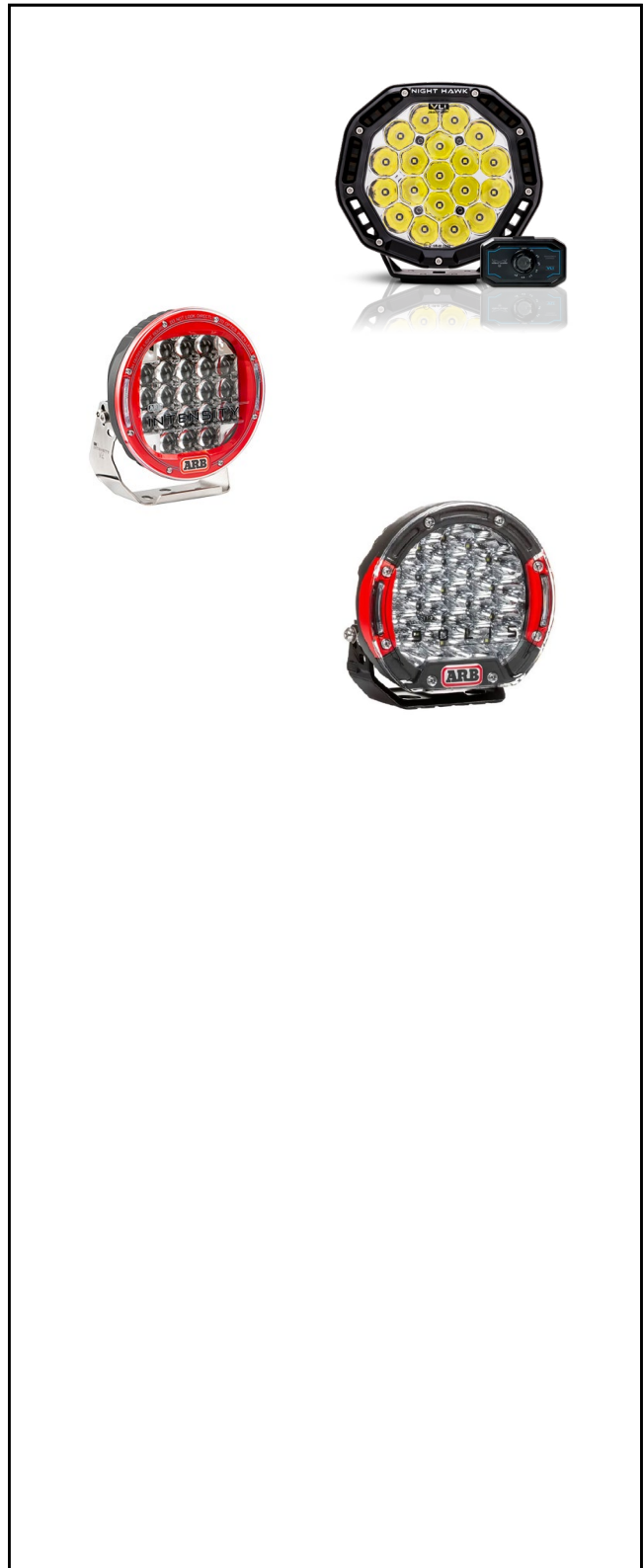



PART NUMBER MATRIX

SPARTANBAR TOYOTA HILUX 06/2020-2/2023

| Fitting Time | 3 Hours | 4 Hours | 10 Mins | 30 Min | 30 Mins | 15 Mins | 15 Mins |
|--|---------------------------|------------|-----------------|----------|----------------------------|---------|---------|
| 4x2 Toyota Hilux | Model (Guide Only) | | | | | | |
| 4x2 Low Rider (Narrow Body) ¹⁰ | SA172BL172 | NA | NA ⁴ | NA | BP80052 | BP80628 | NA |
| 4x2 Hi-Rider (Narrow Body) ¹⁰ | SA172BL172 | NA | NA ⁴ | NA | BP80052 | BP80628 | NA |
| 4x2 Hi-Rider (Wide Body) | SA170BL170 | NA | SA268FK | NA | BP80052 | BP80628 | NA |
| 4x2 Hi-Rider (Wide Body) Parking Sensor Vehicles | SA268BL170 | NA | SA268FK | SA170CRK | NA (Included) ¹ | NA | BP80628 |
| 4x4 Toyota Hilux | Model (Guide Only) | | | | | | |
| 4x4 (Narrow Body) ¹⁰ | SA172BL172 | SA172BL189 | NA ⁶ | NA | BP80052 | BP80628 | NA |
| 4x4 (Wide Body) | SA170BL170 | SA170BL171 | SA268FK | NA | BP80052 | BP80628 | NA |
| 4x4 (Wide Body) Parking Sensor Vehicles | SA268BL170 | SA268BL171 | SA268FK | SA170CRK | NA (Included) ¹ | NA | BP80628 |

Please note:

- ¹ SmartBar for SR5 model is supplied with DRL as standard
- ² Only Narrow Body 4x4 option is the Single-Cab SR and WorkMate
- ³ Only available in black, other colour options available in larger quantities
- ⁴ Workmate 4x2 Single-Cab Cab-Chassis & Double-Cab Pick-Up do not require the infill kit SA268FK
- ⁵ Workmate 4x2 Hi-Rider Single-Cab Cab-Chassis does not require the infill kit SA268FK
- ⁶ Workmate & SR 4x4 Single-Cab Cab-Chassis do not require the infill kit SA268FK
- ⁷ Compatible with Toyota Safety Sense vehicles
- ⁸ SmartBar is not compatible with 06/20+ Rogue or Rugged X models
- ⁹ Required for models that feature front cameras
- ¹⁰ Narrow body SA172 bars are not compatible with ARB recovery points